

# 使用说明书 Instructions for operation

使用产品前请仔细阅读本使用说明书，并保留备用。  
Before using product, read these Instructions for operation carefully and retain it for future reference.

# TOTO

# TOTO

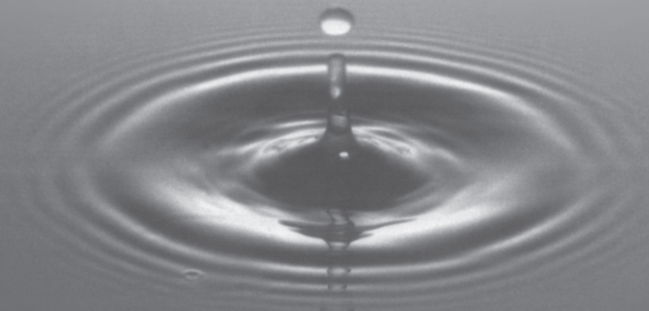

OG477YIA1  
2018.06

# 目录

## 目 录

目录.....	1
明细单 .....	2-3
使用条件与使用上的注意 .....	4
使用上的注意与保养 .....	5
产品示意图 .....	6-7
拆卸与检查 .....	8-9
产品保修卡 .....	10
合格证 .....	11

# 明细单

## 明细单

淋浴器.....	1套
淋浴软管.....	1根
使用说明书 .....	1本
施工说明书 .....	1本

使用本明细单的产品包括:

TBW01008B2	手持花洒(圆形单功能)
TBW01008B2#PG	手持花洒(圆形单功能)
TBW01010B2	手持花洒(圆形多功能)
TBW01010B2#PG	手持花洒(圆形多功能)

# 明细单

## 明细单

淋浴支架·····	1套
主体部·····	1套
使用说明书·····	1本
施工说明书·····	1本

使用本明细单的产品包括:



TBW01031B 淋浴支架  
TBW01031B#PG 淋浴支架

# 使用条件与使用上的注意

## 使用条件

1. 供冷水\*热水压力:  
最低压力·····0.05MPa (流动压)  
最高压力·····0.75MPa (静压)  
推荐使用压力·····单功能0.12MPa (流动压) -0.5MPa (流动压)  
多功能0.15MPa (流动压) -0.5MPa (流动压)
2. 供水温度在4℃~60℃, 建议使用热水温度60℃以下, 供热水请勿使用蒸汽。
3. 使用环境温度1~40℃。如果低于0℃, 水嘴会出现变形、冻裂等现象。
4. 为防止花洒内部损坏, 花洒侧吐水温度不得超过60℃, 建议使用温度45℃以下。
5. 长时间不使用时, 可能导致水嘴内部及外部锈蚀不能使用等现象。
6. 如果您需要废弃本产品, 请勿将其作为一般生活垃圾处理, 请依照法规经由独立的回收体系进行合适的处理、恢复和回收。
7. 本说明书中的产品具有清洗功能。

## 使用上的注意

-  **警告** 表示如果无视此标志而误操作时, 有可能造成人员重伤或死亡。
-  **注意** 表示如果无视此标志而误操作时, 有可能造成人身伤害或财产损失。

### 警告

1. 幼儿禁止使用或幼儿需要由成年人监护使用、老人和残障人士等特殊群体应在有行动能力人员陪同下使用。
2. 水嘴的供热水一侧处于高温状态, 请勿使皮肤直接接触五金配件表面, 否则可能会烫伤。
3. 供热水请勿使用蒸汽, 否则可能会烫伤。
4. 当直接从吐水口侧切换到淋浴器侧或从淋浴器侧切换到吐水口侧时, 水温会发生变化, 要用手测试水温后再使用, 否则可能会烫伤。

# 使用上的注意与保养

## ⚠注意

1. 请勿撞击本产品，否则可能会造成故障、漏水。
2. 必须使用中性洗涤剂清洗，中性以外的洗涤剂会破坏镀层或使表面变色。
3. 不得使用酸性洗涤剂和去污粉、抛光粉等含粗颗粒的洗涤剂和尼龙刷，否则可能会破坏镀层等。
4. 可使用软布擦拭，间或用机油或车用蜡浸布擦拭，但请勿接触树脂部件，否则可能失去光泽和产生锈蚀。
5. 建议不要长时间不使用，否则可能导致水嘴内部以及外部锈蚀不能使用等现象。
6. 随着产品式样的不断更新，实物存在与图示不符的情况，但基本安装、使用原理相同。

## 保养

为长期保持产品的美观，请用户按以下方法维护保养。

1. 经常用软布擦拭，间或用软布蘸水擦拭。
2. 当有污垢且比较明显时，请用中性洗涤剂擦拭后充分进行水洗。
3. 散水板的保养与维护：

- 轻度脏的场合，将软布用温水浸湿后拧干擦拭。
- 重度脏的场合，用软布蘸取适量中性洗调剂擦拭后用清水充分清洗，再用软布擦干。
- 当喷嘴有堵塞、流线混乱时，将软布用温水浸湿后拧干擦拭，注意不要将喷嘴划破，如果太用力擦拭，喷嘴容易被划破、变形，从而造成流线变形。

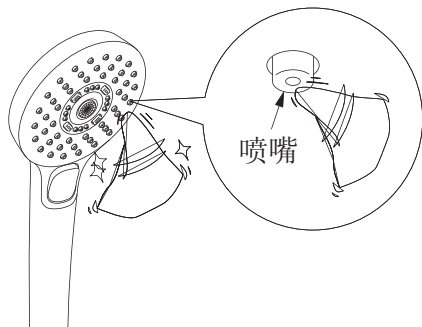

# 产品示意图

TBW01008B2 手持花洒(圆形单功能)

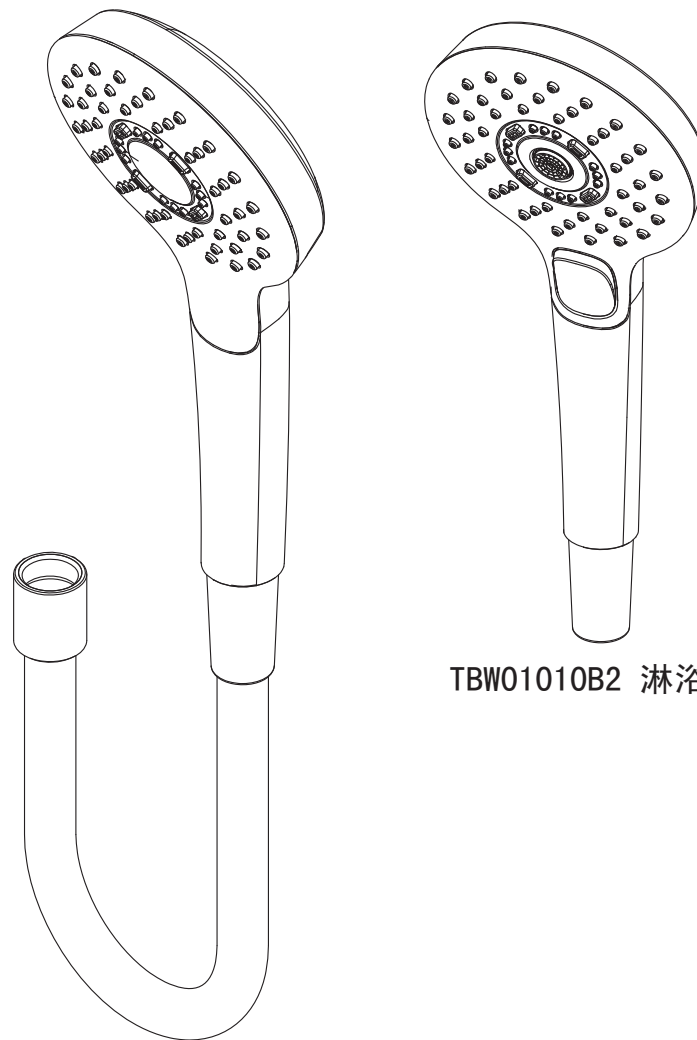

TBW01010B2 淋浴头

# 产品示意图

TBW01031B 淋浴支架

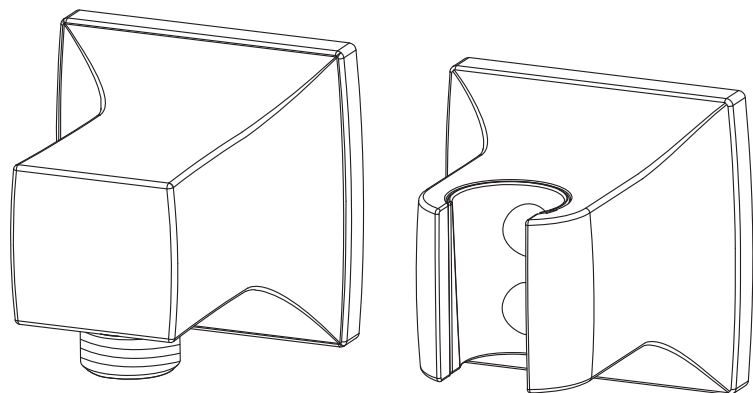

# 拆卸与检查

以TBW01008B2 手持花洒(圆形多功能)为例:

现象	检查项目
漏水	1、4、5
水流量小	2、3

安装后万一出现故障,请按以下要领拆卸。(此图内未拆分的零件,需要拆卸的情况下,请联络售后服务人员进行拆卸)

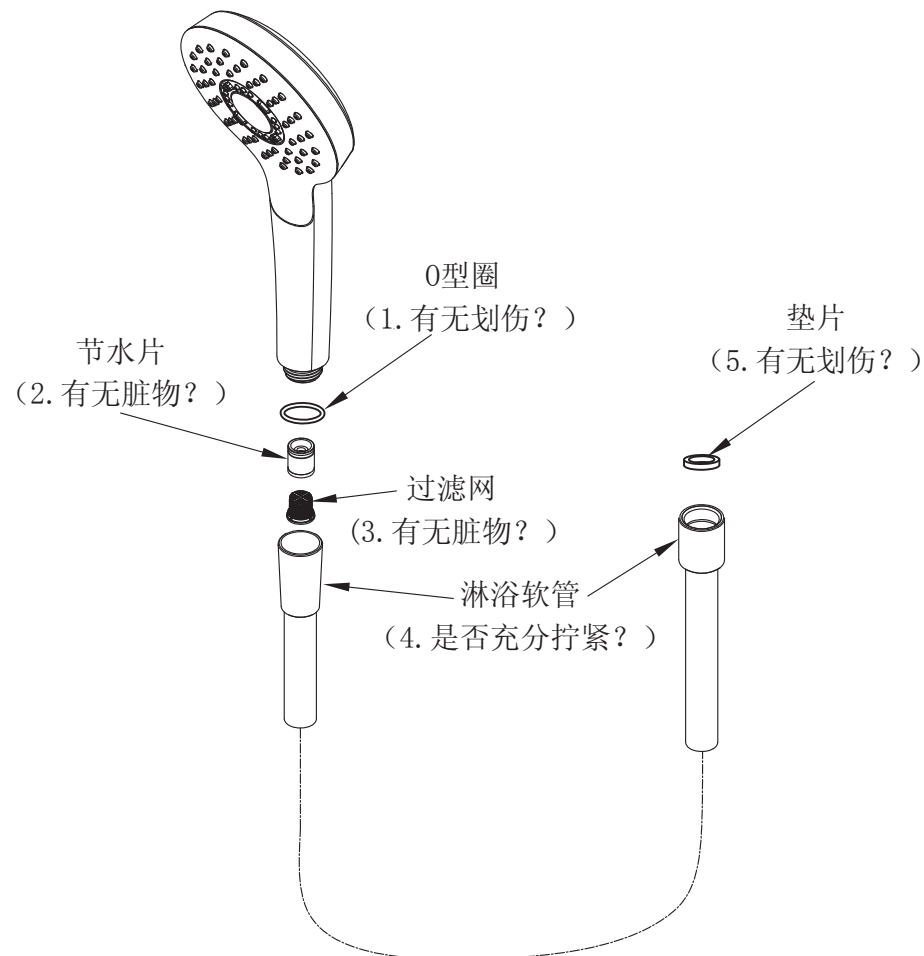

※注意:若出水不良,请用手揉搓几下吐水不良的小橡胶凸起。

# 拆卸与检查

以TBW01031B 淋浴支架为例:

现象	检查项目
漏水	2
支架松动	1
主体松动	3

安装后万一出现故障, 请按以下要领拆卸。(此图内未拆分的零件, 需要拆卸的情况下, 请联络售后服务人员进行拆卸)

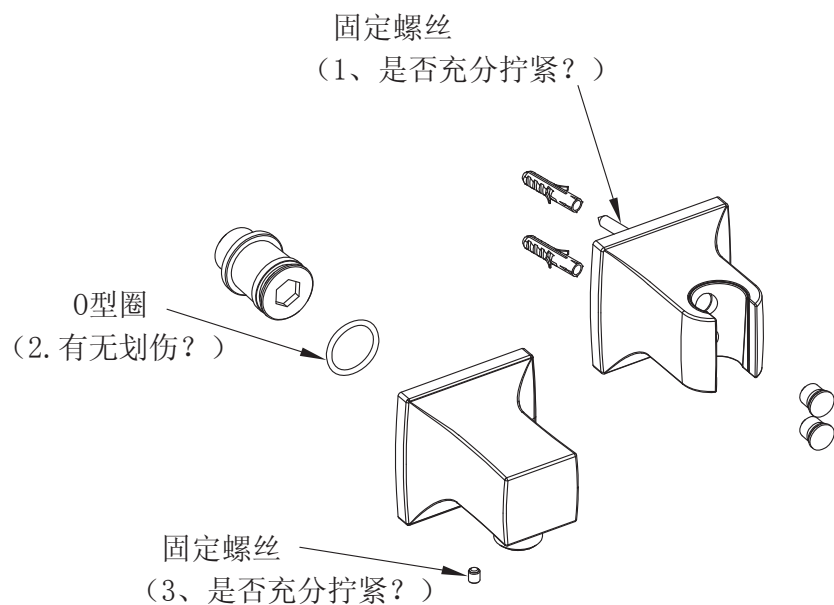

# 拆卸与检查

用户	
销售安装店	
购买日	
保修期	自购买日起本体及阀芯保修有效期5年, 其余部件保修期为1年

- \* 若上栏内容未记全, 该产品保修卡将视为无效。因此请用户购买时对记入内容进行确认。
- \* 本产品保修卡中的保修项目仅限于产品保修卡中所约束的免费维修项目时行维修。
- \* 在保修期间, 若产品发生故障(漏水、渗漏), 请用户向销售店或安装店出示产品保修卡及购买发票、提出修理要求。

## 免费维修规定

1. 保修期间, 在用户正确按说明书、不干胶贴等指示, 使用本公司产品的情况下, 本公司将对有故障产品进行免费维修。
2. 在保修期内发生损坏需得到免费修理时, 请持本产品保修卡和购买发票委托安装店或销售店办理。
3. 在保期内, 下面所列场合的维修为有偿维修。
  - ①使用不当或私自进行的不当修理及改造造成的故障及损伤。
  - ②安装施工时的不注意或过失造成的故障及损伤。
  - ③安装后又拆移等原因造成的故障及损伤。
  - ④超出使用范围以外的场合下使用本产品所造成的故障及损伤(如家庭用商品作为业务上商品使用。)
  - ⑤砂粒或污物等造成的损伤。
  - ⑥由于日常的维护保养不当造成的肮脏、电镀部分生锈等不良。
  - ⑦由于火灾、地震、水灾、雷击及其他天灾、公害、气害(液化气)、盐害及异常电压、使用指定外的电源(电压、频率)等原因造成的故障及损伤。
  - ⑧本产品保修卡没指定的场合。
  - ⑨本产品保修卡中用户姓名、销售店、安装店、购买日期未填写的场合。
  - ⑩不能出示购买发票的场合。
4. 本产品保修卡仅适用于中国国内。
5. 本产品保修卡丢失不补, 请顾客妥善保管。

# 合格证

本品经检查判定合格

执行标准：GB T23447-2009、GB 28378-2012  
QB/T 1334-2013(适用于TBW01031B)

产品型号：见包装箱上的标签

产品名称：见包装箱上的标签

生产日期：见包装箱上的标签

组装工厂：东陶（大连）有限公司

电 话： (0411) 87624383

厂 址：大连经济技术开发区东北二街17号

东陶(中国)有限公司

全国售后服务电话：800-820-9787(固定电话)  
400-820-9787(手机用户)

销售商：东陶(中国)有限公司

地 址：北京市朝阳区光华路1号 北京嘉里中心北楼1915

网 址：www.toto.com.cn

# Contents

## Contents

Contents .....	1
Detailed list .....	2-3
Use condition and attentions in use .....	4
Attentions in use and maintenances .....	5
Product schematic diagram .....	6-7
Dismantle and inspection .....	8-9
Product Warranty Card .....	10

## Detailed list

---

### Detailed list

Shower .....1 set  
Shower hose .....1 piece  
Instructions for construction .....1 copy  
Instructions for operation .....1 copy

The products using this detailed list include:

TBW01008B2	"G Shower" 1mode Hand Shower Set (Standard Type)
TBW01008B2 #PG	"G Shower" 1mode Hand Shower Set (Standard Type)
TBW01010B2	"G Shower" 3mode Hand Shower Set (Standard Type)
TBW01010B2#PG	"G Shower" 3mode Hand Shower Set (Standard Type)

## Detailed list

---

### Detailed list

Shower holder .....1 set  
Body .....1 set  
Instructions for construction .....1 copy  
Instructions for operation .....1 copy

The products using this detailed list include:

TBW01031B	Shower holder
TBW01031B#PG	Shower holder



# Use condition and attentions in use

## Use condition

1. Minimum pressure.....0.05MPa (flow pressure)  
Maximum pressure.....0.75MPa (static pressure)  
Recommended Operating pressure.....  
single function 0.12MPa (flow pressure) -0.5MPa (flow pressure)  
multi function 0.15MPa (flow pressure) -0.5MPa (flow pressure)
2. The temperature for water supply is 4~60°C. It is suggested to use the temperature below 60°C. Do not use steam to supply hot water.
3. The ambient temperature for use is 1~40°C. If the ambient temperature is lower than 0°C, the faucet will deform and crack from freezing.
4. To prevent internal spinkler damage, the water outlet temperature on the spinkler side shall not exceed 60°C, it is suggested to use a temperature below 45°C.
5. Being out of use for a long time may result in internal and external rust to the faucet and being unable to be used.
6. If you want to scrap this product, do not treat it as you do for general household garbage. Please follow relevant statutes to have it treated, recovered and collected appropriately by an independent recovery system.
7. The product in these instructions has a cleaning function.

## Attentions in construction

- ⚠ **Warning:** it means that ignoring this mark and misoperation may cause serious personal injury and death.
- ⚠ **Attention:** it means that ignoring this mark and misoperation may cause personal injury or property loss.

### ⚠ Warning

1. Children are not allowed to use or can use only under the custody of adult. Such special groups as the aged and disabled should be accompanied by those with behavioral competence when using it.
2. The hot water supply side of the water nozzle is in a condition of hightemperature. Do not allow skin to contact with the hardware surface directly. Otherwise, scalding may occur.
3. Do not use steam to supply hot water. Otherwise, scalding may occur.
4. The water temperature will change when switch from spout to shower or switch from shower to spout. The user should test it by hand. otherwise, scalding may occur.

# Attentions in use and maintenance

## ⚠ Attentions

1. Do not impact the product. Otherwise, failure, water leakage may occur.
2. It is imperative to use a neutral detergent in cleaning. Other detergents than a neutral one may damage the plating coat or make the surface discolor.
3. Do not use any such detergent as acidic detergent and abstergent, polishing powder, etc. containing thick particles and nylon brush. Otherwise, the plating coat may be damaged, etc.
4. It is allowed to use a piece of soft cloth to wipe or use from time to time a piece of cloth immersed in machine oil or vehicle wax to wipe. However, do not contact with resin components. Otherwise, they may lose the gloss and become rusty.
5. It is suggested not to leave it unused for a long time. Otherwise, this may lead to internal and external rust to water nozzle to such a degree that it cannot be used any more, etc.
6. With the product design being updated constantly, the physical object may not coincide with the figure. However, the basic principle for installation, use is the same.

## Maintenance

- In case of mild dirt, use a piece of soft cloth dipped in water and wipe after wringing out.
- In case of severe dirt, use a piece of soft cloth dipped in a neutral cleaner to wipe and then wash with clear water sufficiently. Then use a piece of soft cloth to wipe dry.
- When the nozzle is blocked and the streamline is confused, use a piece of soft cloth dipped in warm water to wipe after wringing out. Take care not to damage the nozzle. If too much force is used in wiping, it is easy for the nozzle to get damaged and deformed. As a result, the streamlines are deformed.

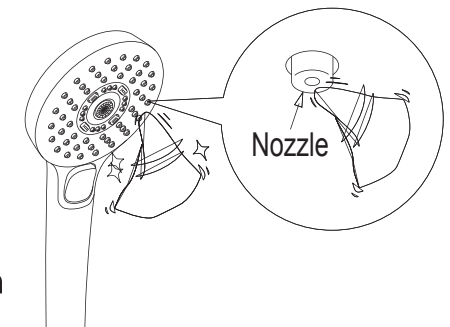

# Product schematic diagram

TBW01008B2 "G Shower" 1mode Hand Shower Set (Standard Type)

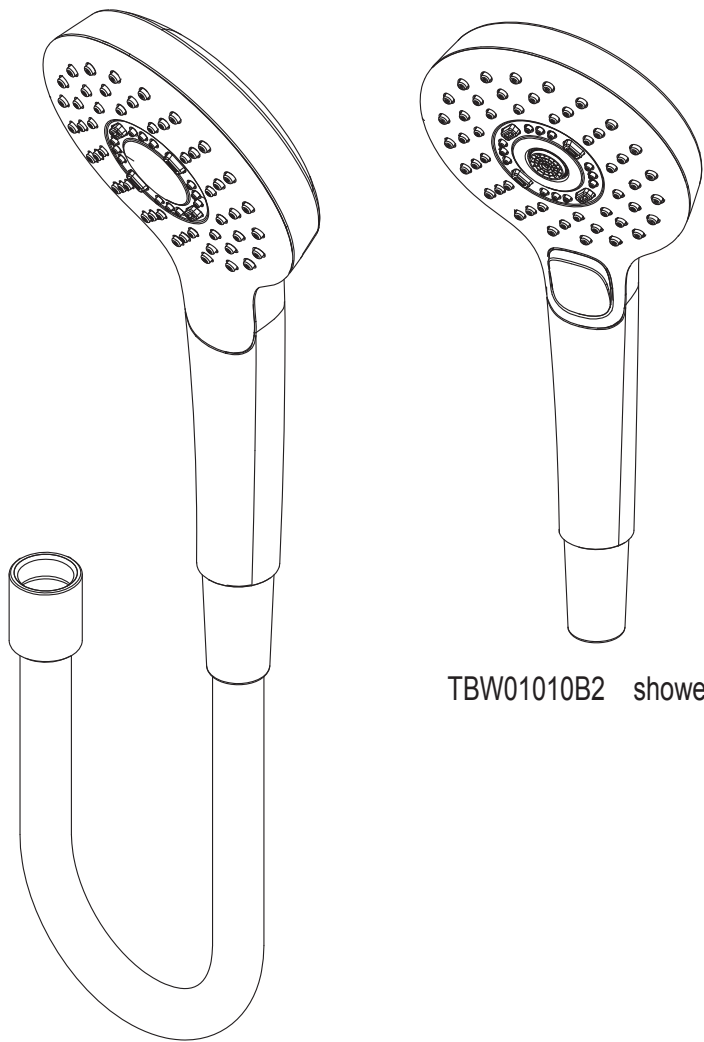

TBW01010B2 shower

# Product schematic diagram

TBW01031B Shower holder

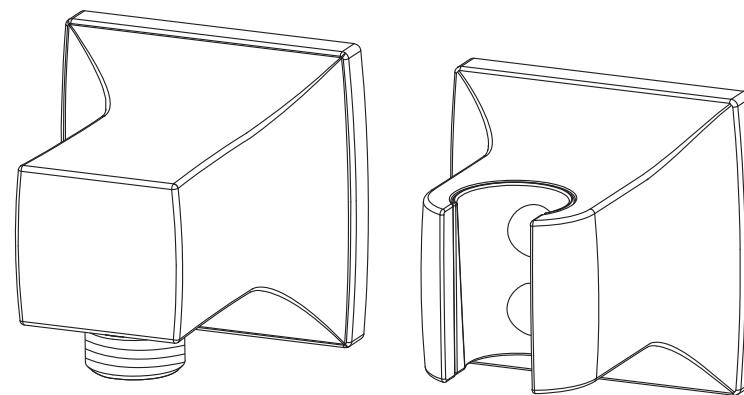

# Dismantle and inspection

TBW01008B2 series used as an example:

Symptom	Inspecting item
Water leakage	1、 4、 5
The water flow is small	2、 3

In case of any failure after installation, please remove according to the following main points. (When any spare part and component not removed in this figure needs to be removed, please contact with relevant after-sale service people for removal)

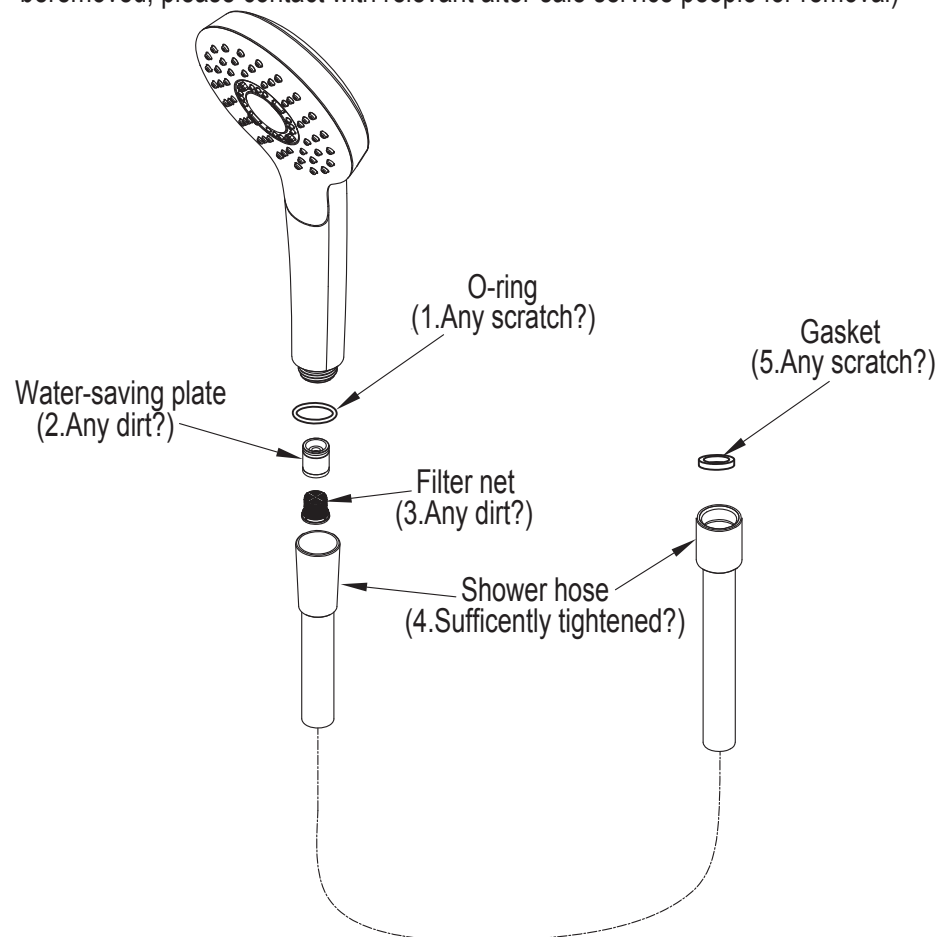

※Note: If the water outlet is poor, please rub with hand the small rubber convex part for several times

# Dismantle and inspection

TBW01031B series used as an example:

Symptom	Inspecting item
Water leakage	2
The support becomes loose	1
The body sways	3

In case of any failure after installation, please remove according to the following main points. (When any spare part and component not removed in this figure needs to be removed, please contact with relevant after-sale service people for removal)

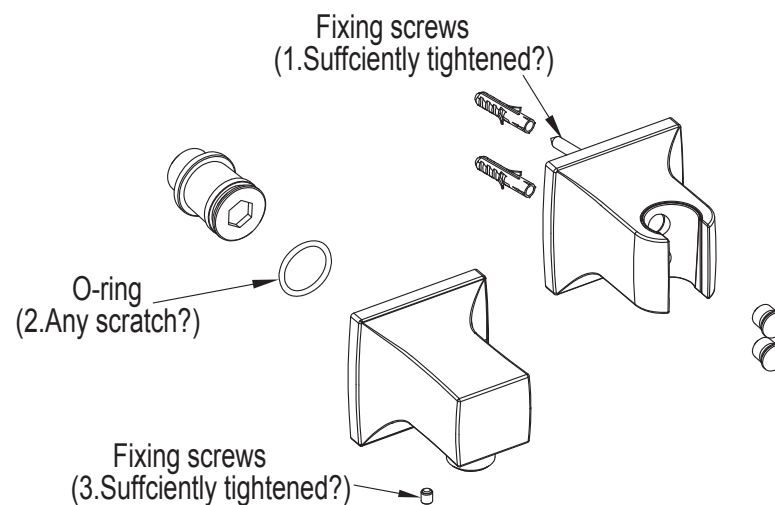

# Product Warranty Card

User	
Sales shop or installation shop	
Date of buying	
Warranty period	The warranty is effective for a period of one ( 1 ) year from the date of purchase.

- \* If the contents in the above column are not complete, the product warranty card shall be deemed as invalid. Therefore, user should confirm the contents put in at the time of buying.
- \* The items covered in this product warranty card are only limited to repair to those free repair items as agreed in the product warranty card.
- \* During the warranty period, if any failure occurs to the product (water leakage, seepage), the user is requested to show the product warranty card and buying invoice to the sales shop or installation shop for making a repair requirement.

## Free Repair Regulations

1. During the warranty period, if the user uses the products of the company correctly according to relevant instructions, adhesive labels, the company will provide free repair to any faulty product.
2. When any free repair is required due to damage within the warranty period, please bear this warranty and the buying invoice to entrust the installation shop or sales shop to handle it.
3. Within the warranty period, the repair in the following occasions is paid repair.
  - ① Any failure and damage due to any improper use or any improper repair and modification conducted privately.
  - ② Any failure and damage resulting from any carelessness or fault in installation construction.
  - ③ Any failure and damage attributed to such reasons as removal for relocation after installation, etc.
  - ④ Any failure and damage due to using this product in occasions beyond the specified scope of use (for example, home commodity is used for any business purpose).
  - ⑤ Any damage caused by sand grains or dirt, etc.
  - ⑥ Such adverse results as dirtiness, plating part rusting, etc. attributed to improper daily maintenance and care.
  - ⑦ Any failure and damage due to fire, earthquake, flood, lightning strike and other natural disasters, public nuisances, gas damage (liquefied gas), salt damage and abnormal voltage, use of any power supply (voltage, frequency) other than the specified ones, etc.
  - ⑧ The occasions not specified in this warranty.
  - ⑨ The occasion in which the user name, sales shop, installation shop or buying date is not filled in.
  - ⑩ No buying invoice can be presented.
4. This warranty applies to countries except China.
5. This product warranty card shall not be reissued when being lost. Customers are requested to keep it properly.

TOTO Asia Oceania Pte. Ltd.

Telephone:65-6744-6955

FAX: 65-6841-0819

Address: 10 Eunos Road 8 #12-07 Singapore Post Centre  
Singapore 408600

Website:asia.toto.com

TOTO KOREA LTD.

전화번호 : (02)-3141-8236

FAX 번호 : (02)-3141-8240

주소 : 서울시 마포구 상수동 351-16번지 로이코빌딩 3층

홈페이지 : <http://www.totokr.co.kr>