

TOTO

入墙水箱安装说明书

THE INSTALLING INSTRUCTION FOR CONCEALED TANK

重要提示:

1. 安装前请仔细阅读说明书, 本公司不承担因安装人员未按说明书要求施工所造成的损失。产品中包含润滑剂, 安装马桶时选用。
2. 在支架安装前, 应先确认安装位置, 并根据室内装修的总体策划确定装修完成后的地坪面FFL, 在安装墙上划出FFL线, 并始终以此作为高度0的基准线。
3. 在安装支架前, 请确认水泥地板厚度在80mm以上, 且当300kgf以上的力施加于完工后的马桶前端时, 地板应能承受这股拉力。

- 注:**
1. 请在贴瓷砖前安装本产品; 所有的尺寸单位为毫米。
 2. 图示零件若与实物不符, 请以实物为准。

⚠ FFL ∇ 0 = 完成面地坪。

配件一览表: Accessories List:

Important remind:

1. Please read through this Instructions carefully prior to installation, and our company shall not be responsible for any loss caused by not installing according to this Instructions. There are lubricants in production for toilet bowl installation.
2. Please confirm the FFL according to the overall indoor fitment method. Line out the FFL on the wall and always regard FFL as datum line of 0 height.
3. Please confirm the thickness of the floor exceed 80mm and it can bear more than 300kgf strength when the strength act on the front of toilet bowl.

Note:

1. Please install the frame before paving the tiles. The dimensional unit is millimeter.
2. Please subject to the object as right if it is not in conformity with the components in picture.

⚠ FFL ∇ 0 = FFL of finish face, all dimension is millimeter

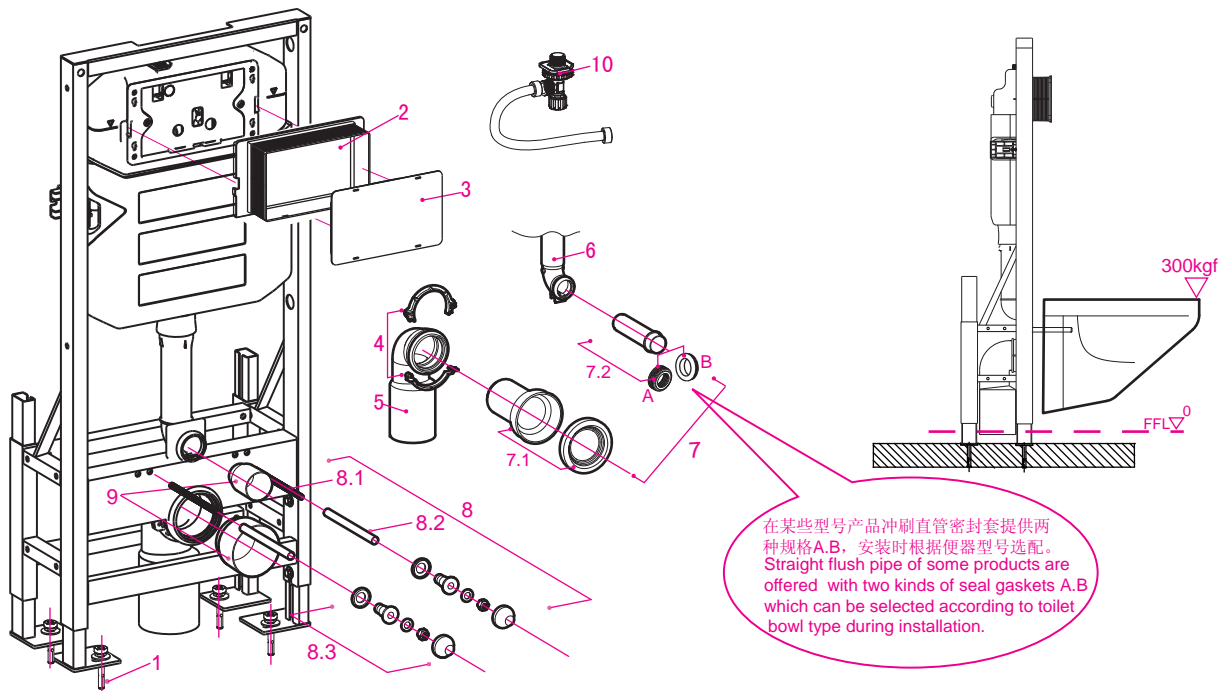

NO.	名称 NAME	数量 QTY	用途 FUNCTION
1	膨胀螺栓组 Expansion bolt components	4	机架固定用 To fix frame
2	保护框 Protection frame	1	砌墙时为按钮面板预留空间用 For space reservation of push button plate when building the wall
3	保护盖 Protection cover	1	防止装修时杂物进入水箱 To prevent sundries falling into the tank when fitment
4	管夹 Clamp	1	固定排污弯管用 To fix drainage pipe
5	排污弯管 Drainage pipe	1	便器排污管道 To drain
6	冲刷弯管 Flush pipe	1	便器供水管道 To supply water to flush
7.1	排污直管件 Drainage straight pipe components	1	用于便器的连接及与墙面距离的补偿 To connect the bended pipes to toilet bowl
7.2	冲刷直管件 Flush straight pipe components	1	
8.1	长螺杆 Long bolt	2	固定便器用 To fix toilet bowl
8.2	透明杆套 Transparent long bolt shield	2	保护长螺杆用 To shield long bolt
8.3	固定便器零件组 Long bolt components	2	固定便器用 To fix toilet bowl
9	堵头 Plug	1	砌墙时为冲刷直管和排水直管预留空间用 To reserve space for straight pipes when laying bricks
10	角阀 Angle valve	1	进水阀开关 On-off For Filling Water

一、基本尺寸及供水管道铺设：
1. Dimensions and Supply Pipe-laying

水箱顶孔进水
Top inlet

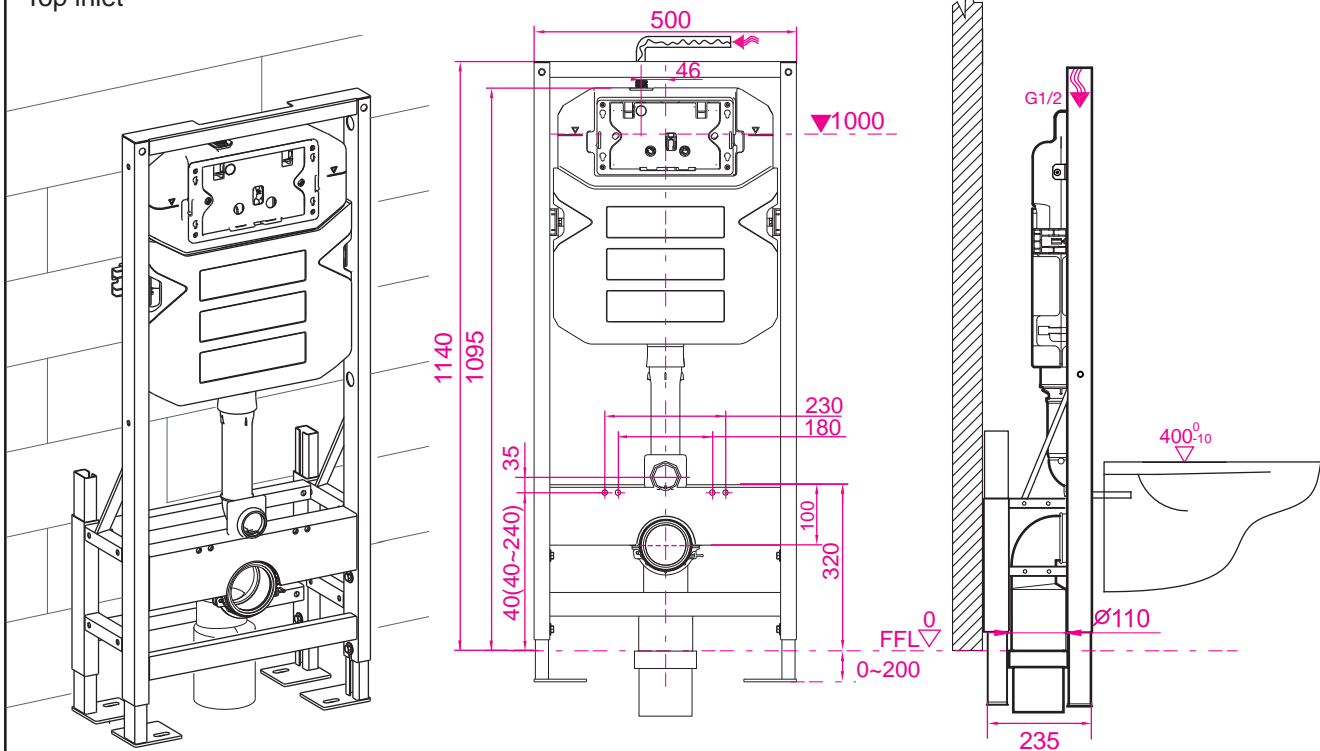

水箱后孔进水
Back inlet

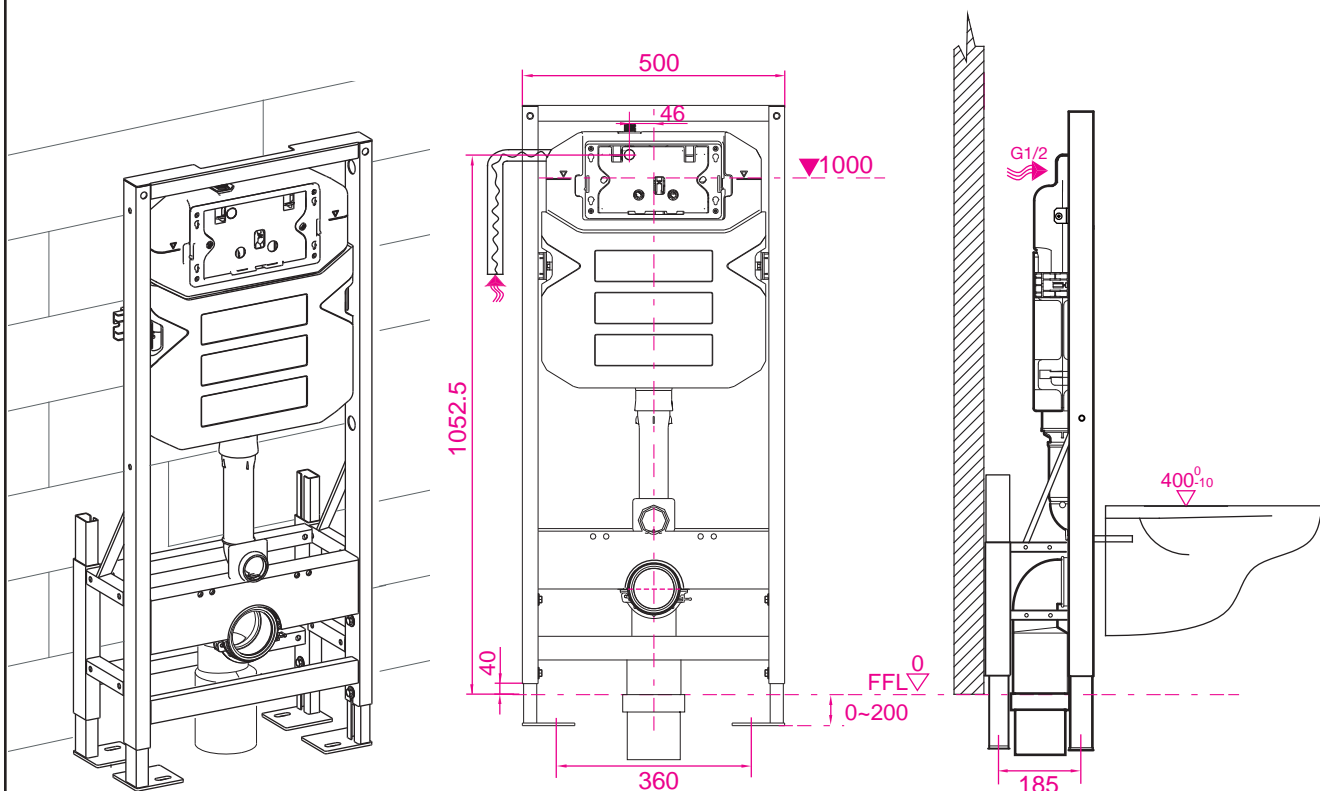

二、排污管安装: 2. Drainage Pipe Installation

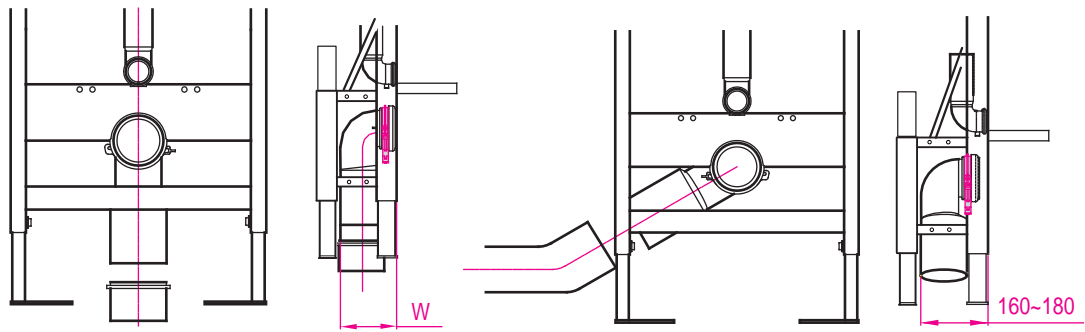

提示：排污管侧向安装角度一般不超过45°，
否则很可能会影响排污效果。

Remind: The function of drainage would be worse when the installation angle of drainage pipe exceed 45°

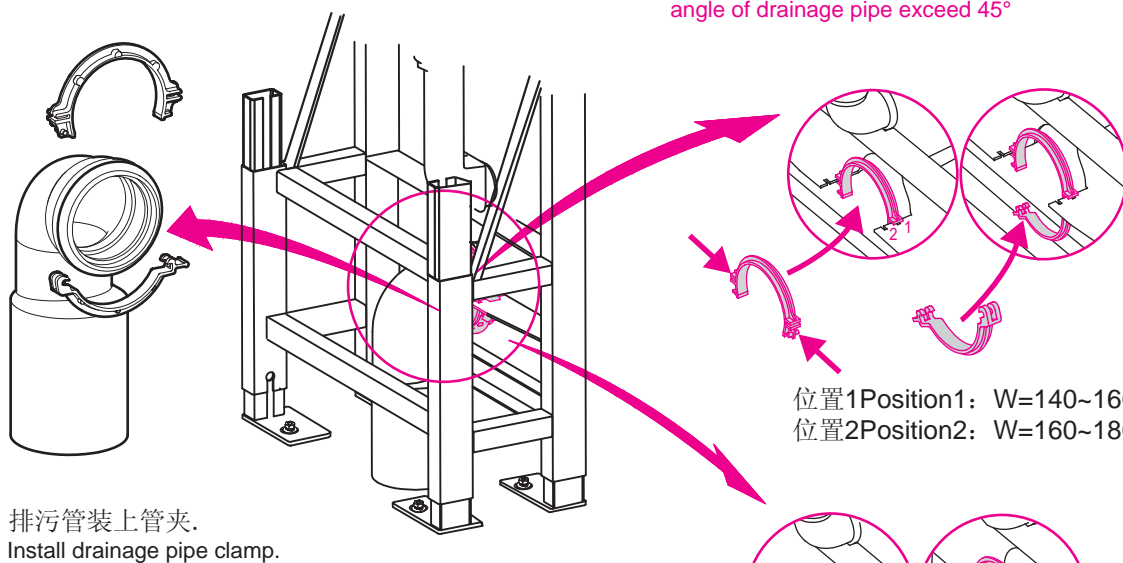

排污管装上管夹。
Install drainage pipe clamp.

位置1 Position 1: W=140~160
位置2 Position 2: W=160~180

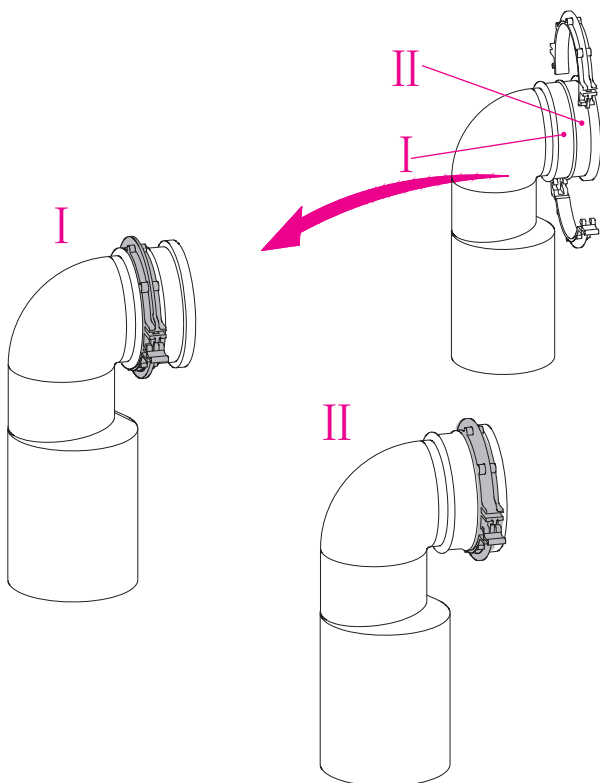

排污管侧向45度输出时，只能装在位置2(W=160~180)

When excretory tube lean 45° ,
it can only be fixed in Position 2(W=160~180).

必要时. 根据马桶尺寸调整管夹和排污管位置。
(非专业人员请勿松开此管夹)

If necessary, adjust the clamp and drainage pipe location
according to the bowl dimension.
(Keep this clamp tightened to professionals!)

三、在地面钻孔 (Ø10X深50)

3. Drill on the floor. (Ø10XDrill50)

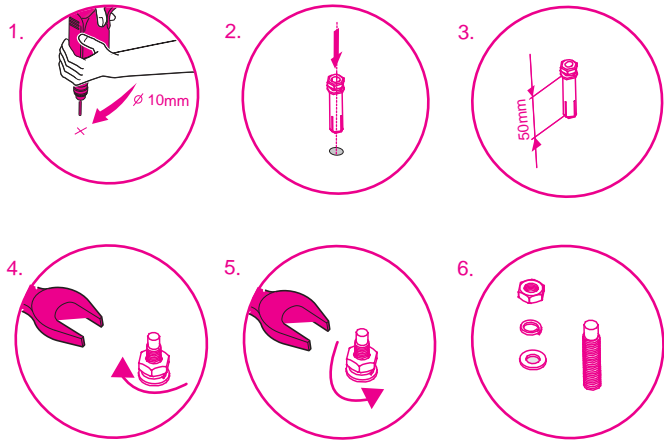
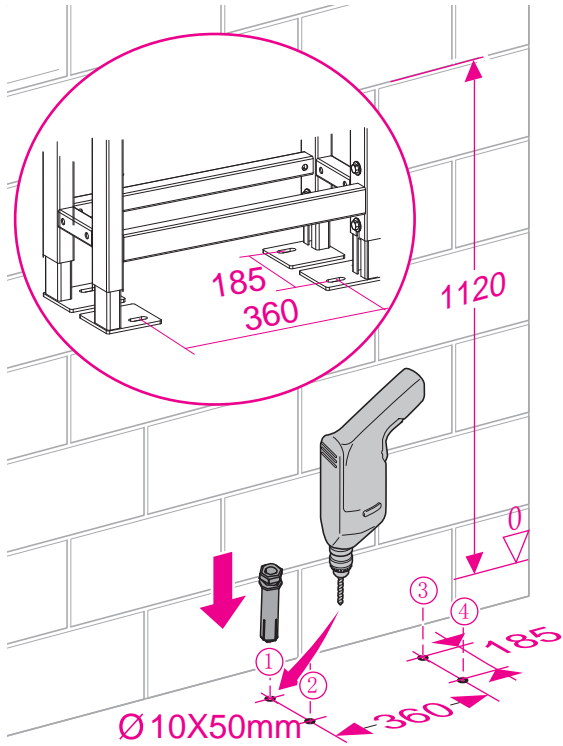

步骤说明:

1. 钻孔 Ø10X深50;
2. 装入膨胀螺栓;
3. 拧紧螺母, 以拉紧螺栓;
4. 旋开螺母;
5. 取走螺母、垫片, 待用

As shown on picture:

1. Drill Ø10*50
2. Insert expansion bolt
3. Tighten nut to strain bolt;
4. Unscrew nut;
5. Hold screw and washer for later use.

四、地脚调节:

4. Adjust floor-fixing bracket :

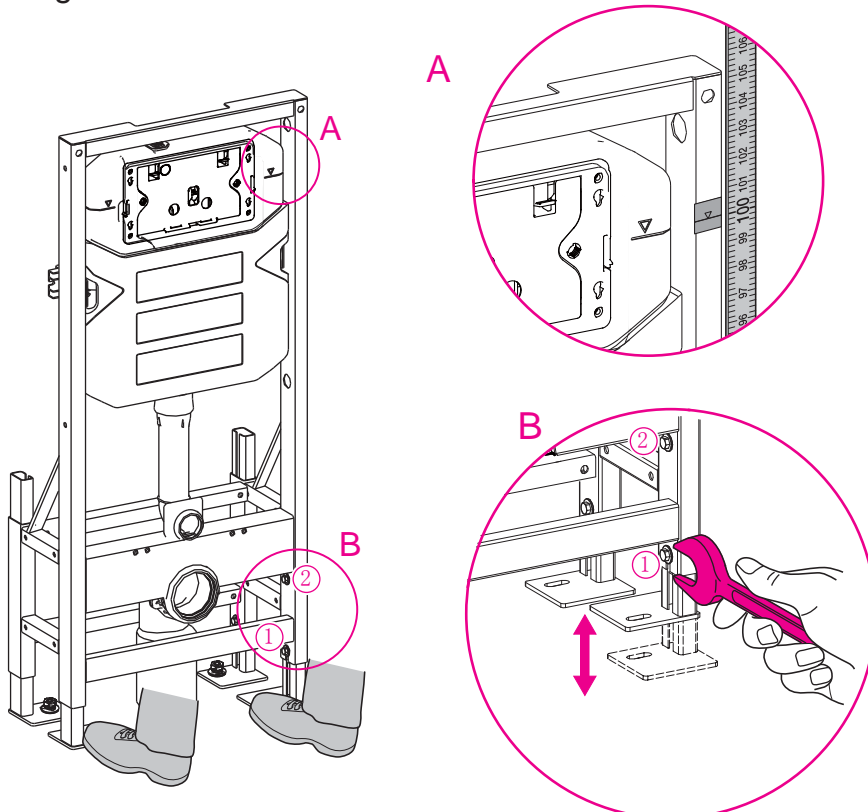

地面固定架。

Floor-fixing bracket.

五、调节机架的水平 and 竖直，并锁紧螺栓：
5. Adjust horizontally and vertically, and tighten bolt:

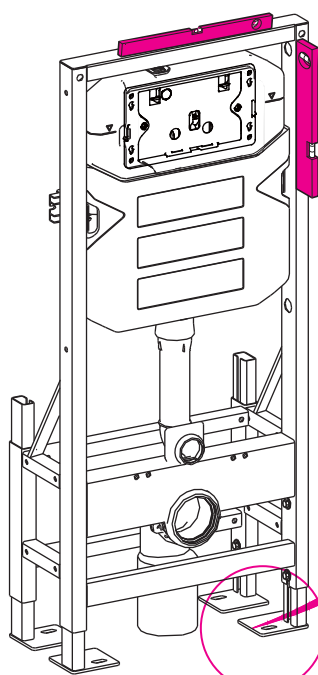

螺栓请先预锁紧，
待机架调整确定后再锁紧。
Please pre-tighten bolt,
and tighten after bracket
adjustment.

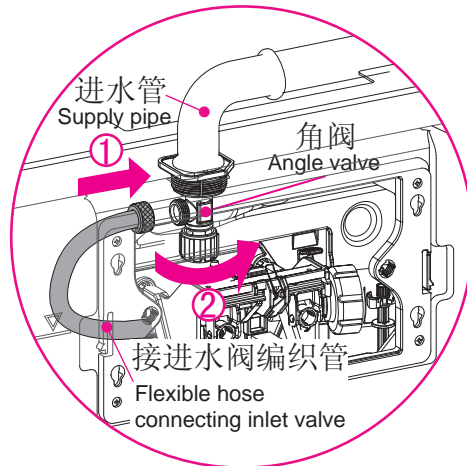
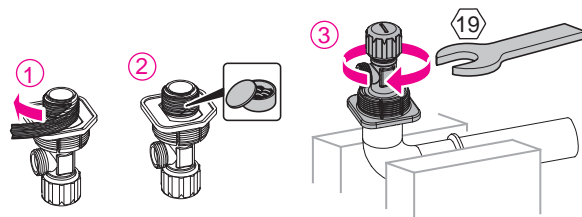

将进水角阀装上并
与编织管和进水管连接。
Install angle valve,
connect it to inlet valve with hose.

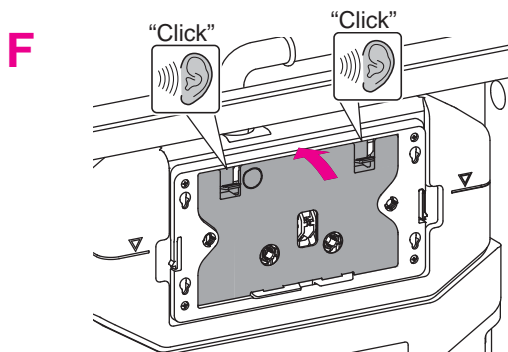
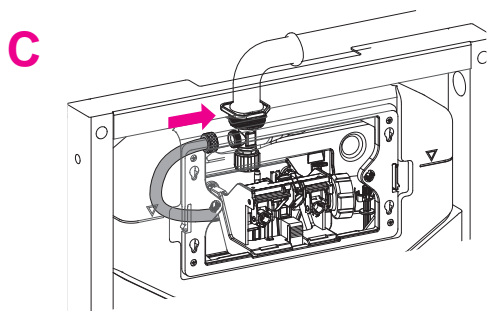
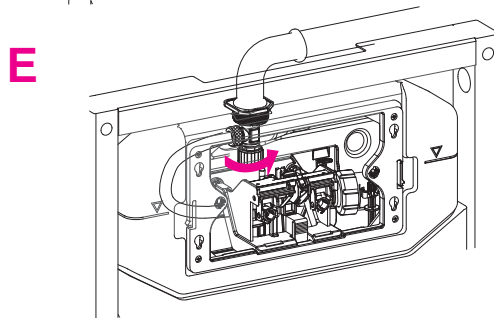
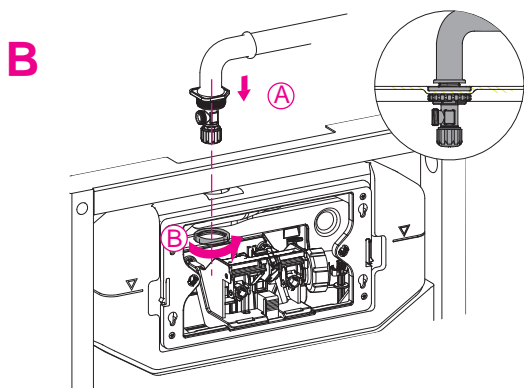
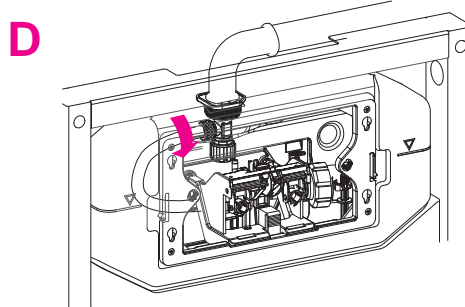
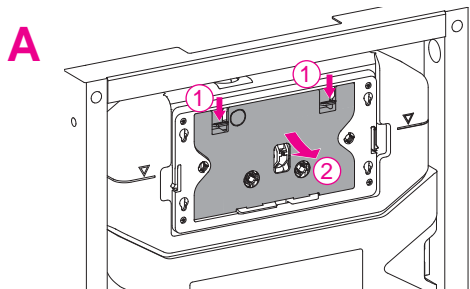

六、装入装修嵌件安装:

6.Install Plug:

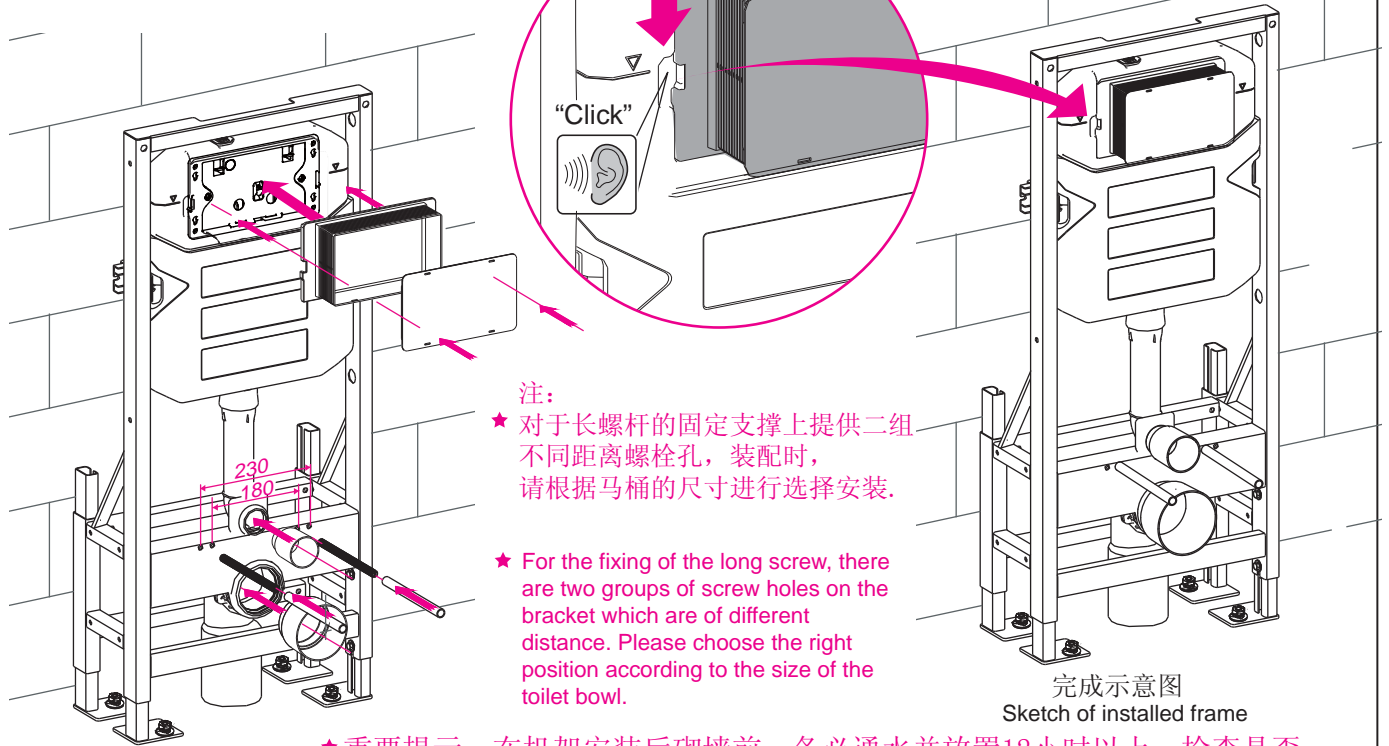

- ★ 重要提示: 在机架安装后砌墙前, 务必通水并放置12小时以上, 检查是否有渗漏现象。
- ★ Important remind: When the concealed tank fixed completely, it is important to test leaking with water upon 12 hours before fixing wall.

七、装修墙厚度范围20~60mm

(从固定机架外面算起, 到贴砖后完成面)

7.The thickness of fixed wall is 20~60mm

(measured from the front of frame to the finished tile surface)

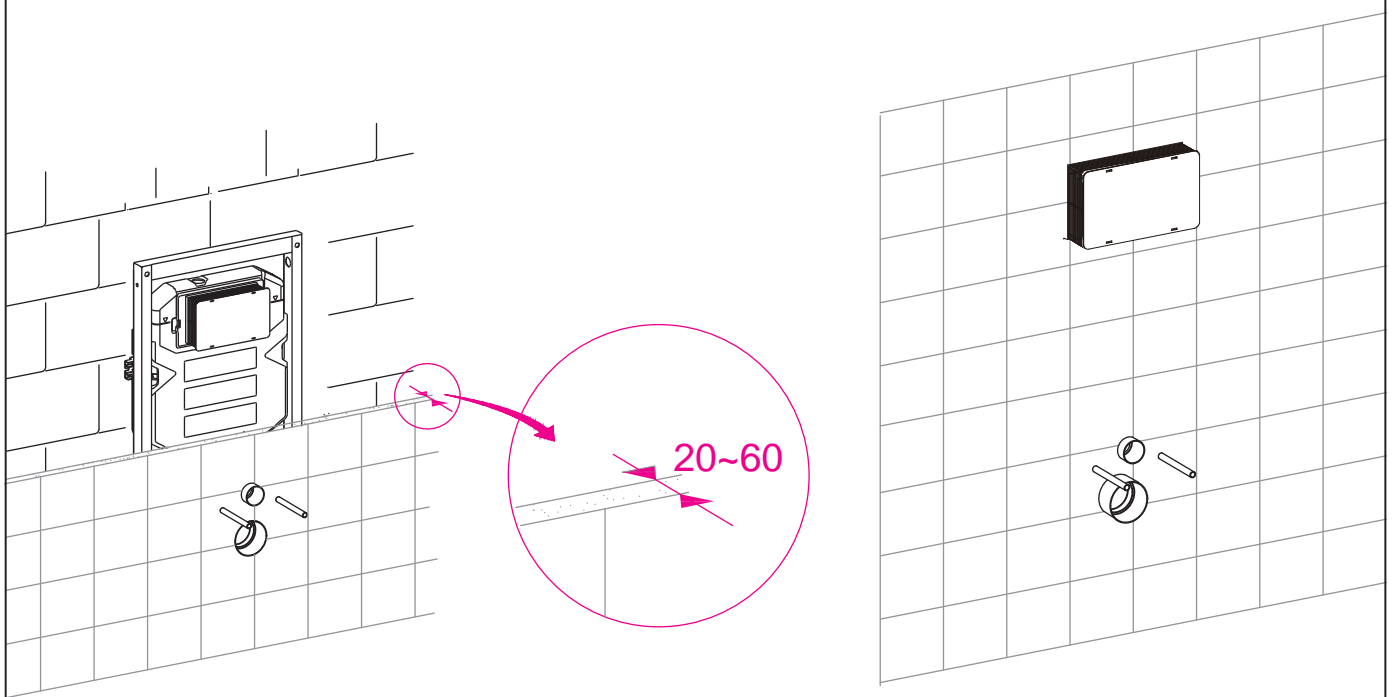

八、安装马桶:

8. Install toilet bowl :

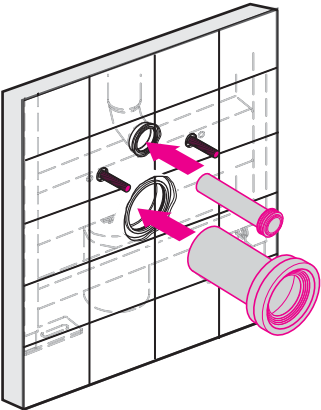
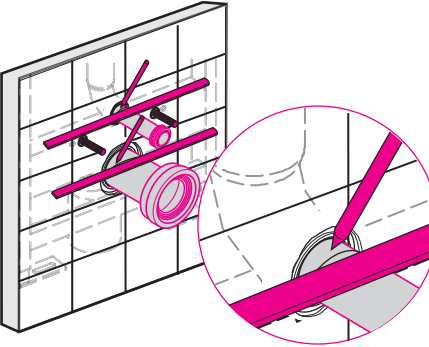
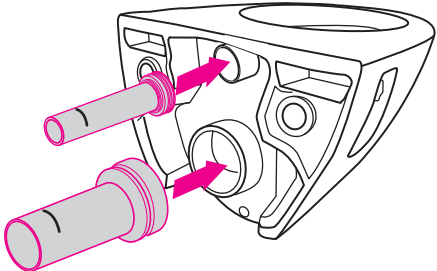
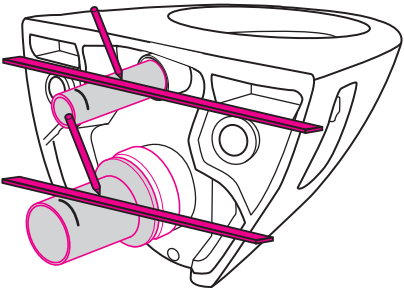
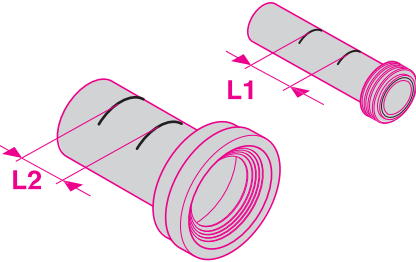
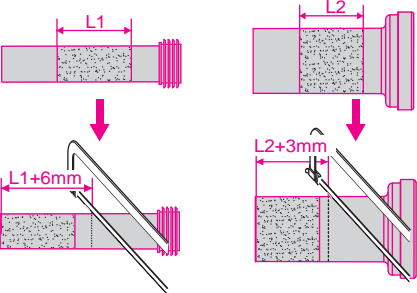
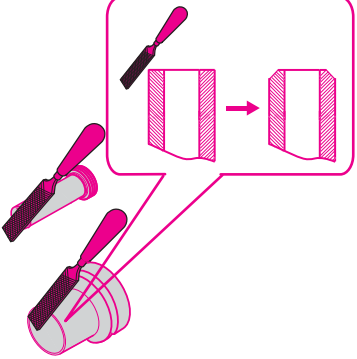
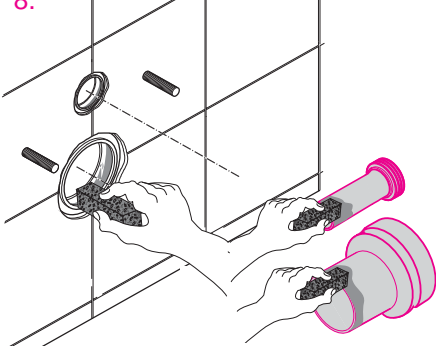
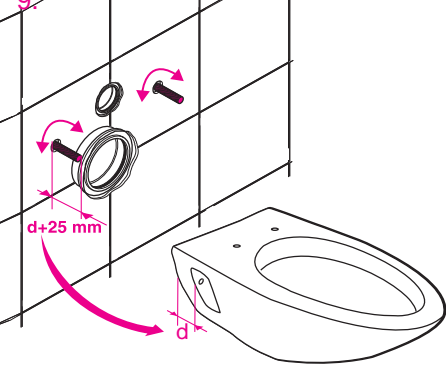
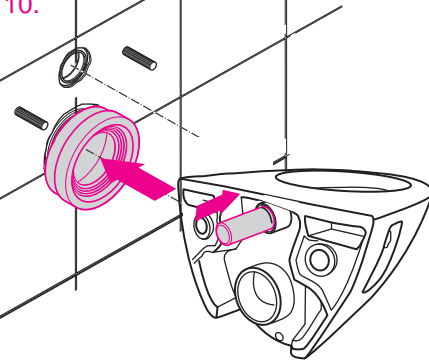
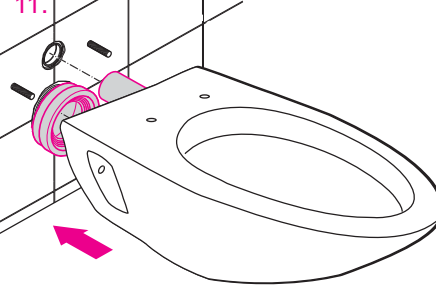
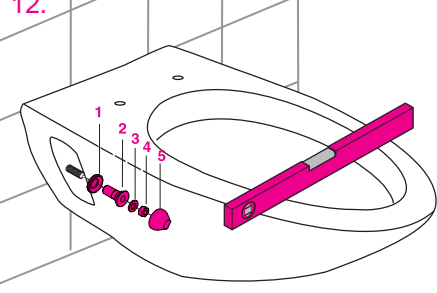
<p>1.</p> 	<p>2.</p>  <p>将直管分别插入冲水管和排水管到位,并画线标识。 Set Straight Pipes into Flush Bend and Drain Bend properly, and marks lines.</p>	<p>3.</p>  <p>分别在两根直管橡胶垫上抹上润滑油,再插入马桶。 (冲刷直管密封套安装方式见3.1、3.2、3.3) Add lubricant onto the Rubber Gaskets of two Straight Pipes and set them into Bowl. (Flush Pipe seal Gasket assembly see 3.1, 3.2 and 3.3)</p>
<p>4.</p>  <p>如图画线标识。 Mark lines as shows.</p>	<p>5.</p>  <p>冲水直管所画线标识之间L1; 排水直管所画线标识之间L2。 L1 is the distance of two marks on Flush Straight Pipe, and L2 is that of two marks on Drainpipe Straight Pipe.</p>	<p>6.</p>  <p>如图切割直管。 Cut Straight Pipe just as shows.</p>
<p>7.</p>  <p>将锯短的两管管口端面打磨倒角(如图),并去除毛边。 Chamfer and trim the cutting edges on the shortened Straight pipes (as shows).</p>	<p>8.</p>  <p>取出带有硅油海绵在直管与弯管的结合处抹上硅油。 Take out the sponge with silicon oil and smear it on connecting edges of Straight Pipe and Bends.</p>	<p>9.</p>  <p>螺杆调节长度为d+25mm(如图) Adjusting length for Bolt is d+25mm as shows.</p>
<p>10.</p>  <p>排水直管插入排水管,再将冲刷直管插入马桶孔。 First install Drain Straight Pipe into Drain Bend, and second install Flush Straight Pipe into Hole on Bowl.</p>	<p>11.</p>  <p>插入马桶。 Install Bowl.</p>	<p>12.</p>  <p>锁定。 Station Bowl properly.</p>

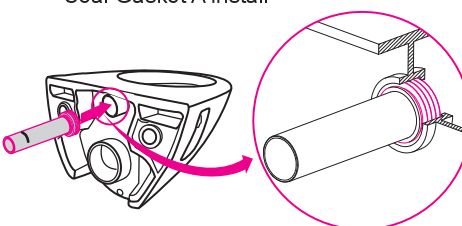
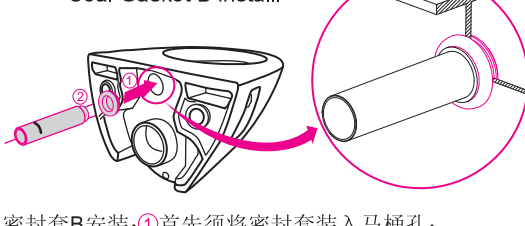
<p>3.1 冲刷直管密封套。 Flush Pipe Seal Gasket.</p>  <p>密封套A Seal Gasket A</p> <p>密封套B Seal Gasket B</p>	<p>3.2 冲刷直管密封套A安装示意。 Seal Gasket A install</p>  <p>密封套安装时连同冲刷直管一起插入马桶孔内。 Seal Gasket A insert into Bowl with Flush Pipe together.</p>	<p>3.3 冲刷直管密封套B安装示意。 Seal Gasket B install.</p>  <p>密封套B安装:①首先须将密封套装入马桶孔; ②然后将冲刷直管塞进密封套B。 Seal Gasket B install: ①install the Gasket into Bowl first; ②then insert the Flush Pipe into the Seal Gasket.</p>
--	---	--

九、水箱配件安装图:
9.Installation of tank fittings:

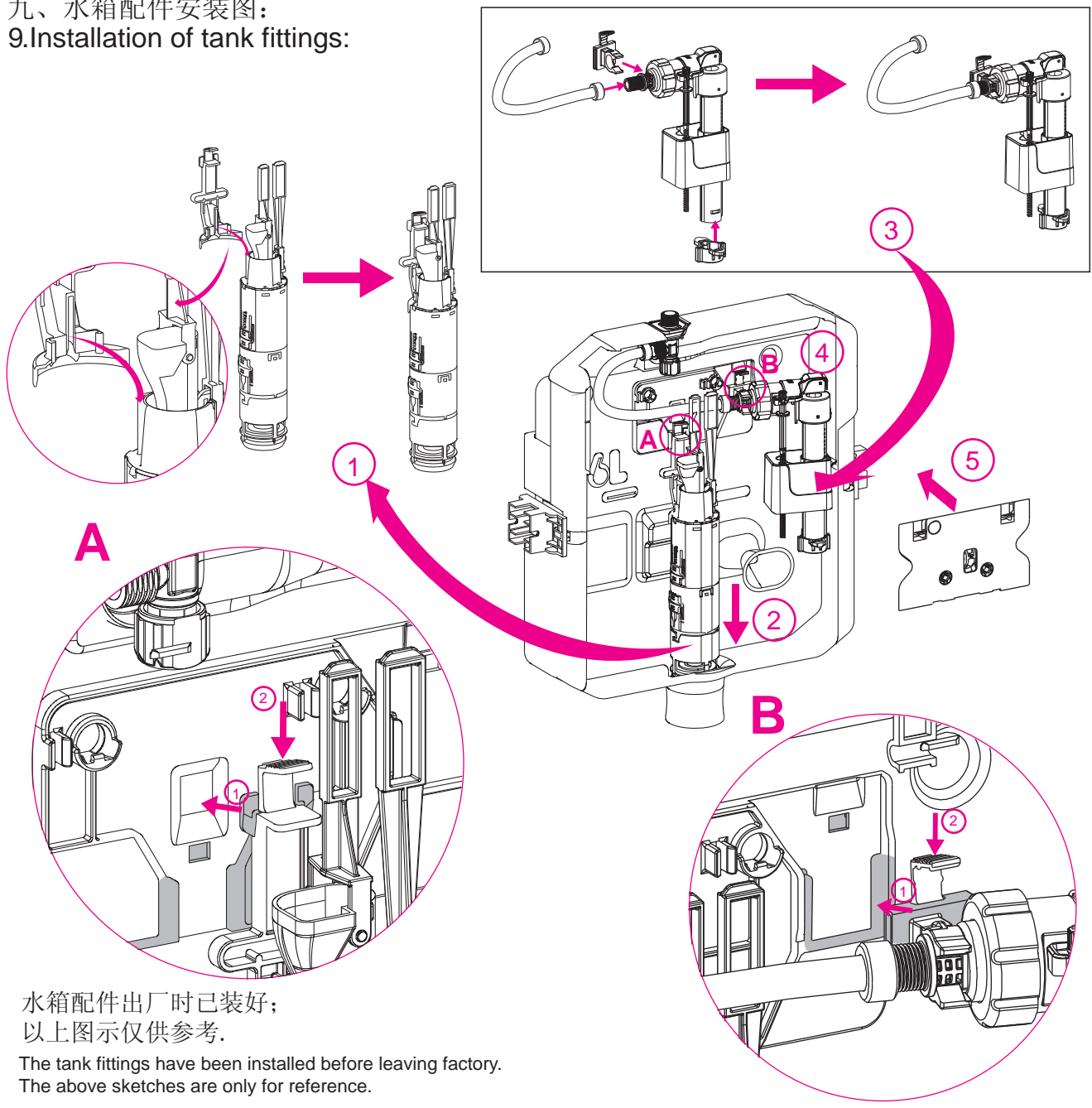

水箱配件出厂时已装好;
以上图示仅供参考。
The tank fittings have been installed before leaving factory.
The above sketches are only for reference.

所有的资料是按出版时的最新产品资料编写的, 本公司保留在任何时候不需通知便可更改产品的特征、包装或供应产品的权利。

All data contained is based upon the last product information available at the time of publication. We reserves the right to implement changes of product characteristics, packaging and availability at any time without further notice.

东陶(中国)有限公司
售后服务全国免费电话: 800-820-9787
手机用户: 400-820-9787

TOTO (CHINA) CO., LTD.
After Service Free Tel: 800-820-9787
Mobile telephone:400-820-9787

五、调节机架的水平 and 竖直，并锁紧螺栓：
5. Adjust horizontally and vertically, and tighten bolt:

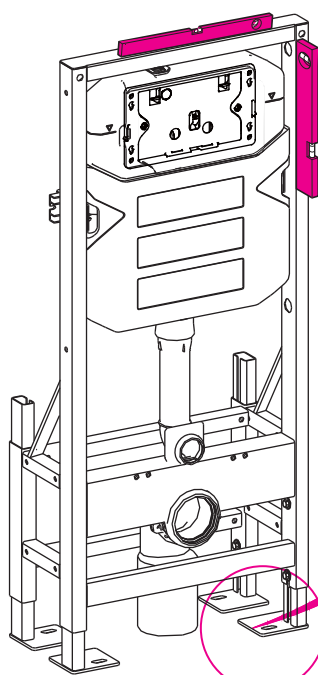

螺栓请先预锁紧，
待机架调整确定后再锁紧。
Please pre-tighten bolt,
and tighten after bracket
adjustment.

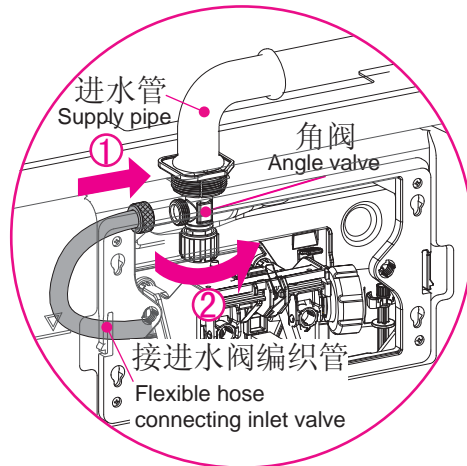
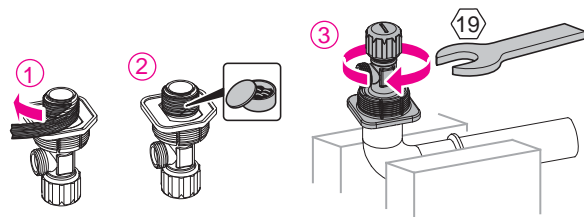

将进水角阀装上并
与编织管和进水管连接。
Install angle valve,
connect it to inlet valve with hose.

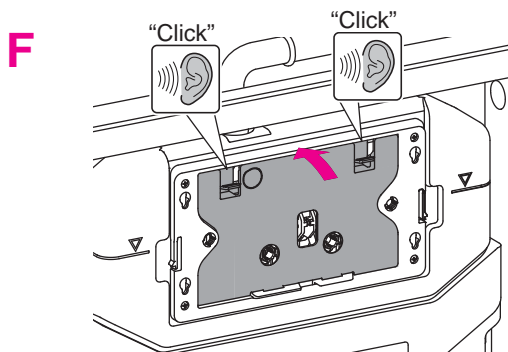
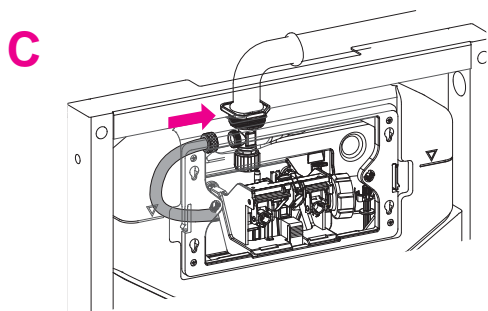
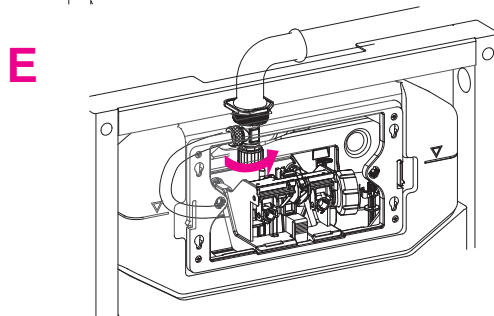
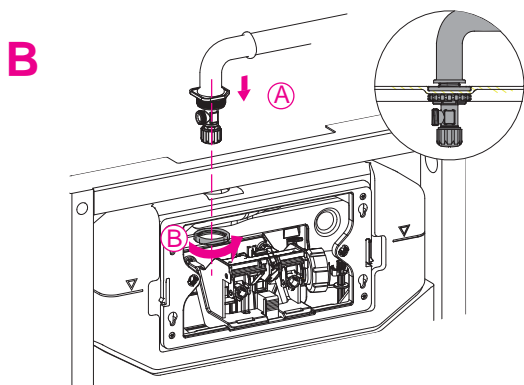
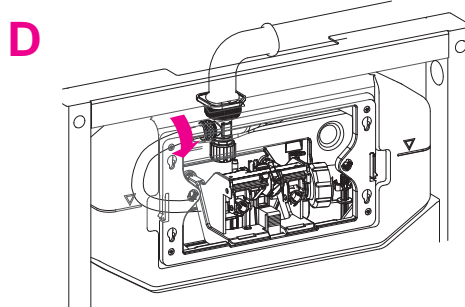
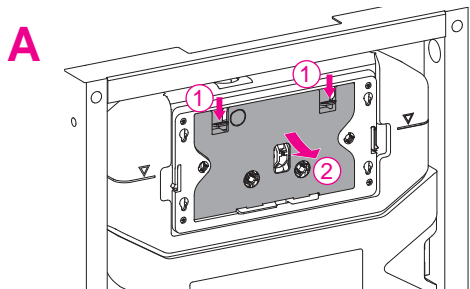

六、装入装修嵌件安装:

6.Install Plug:

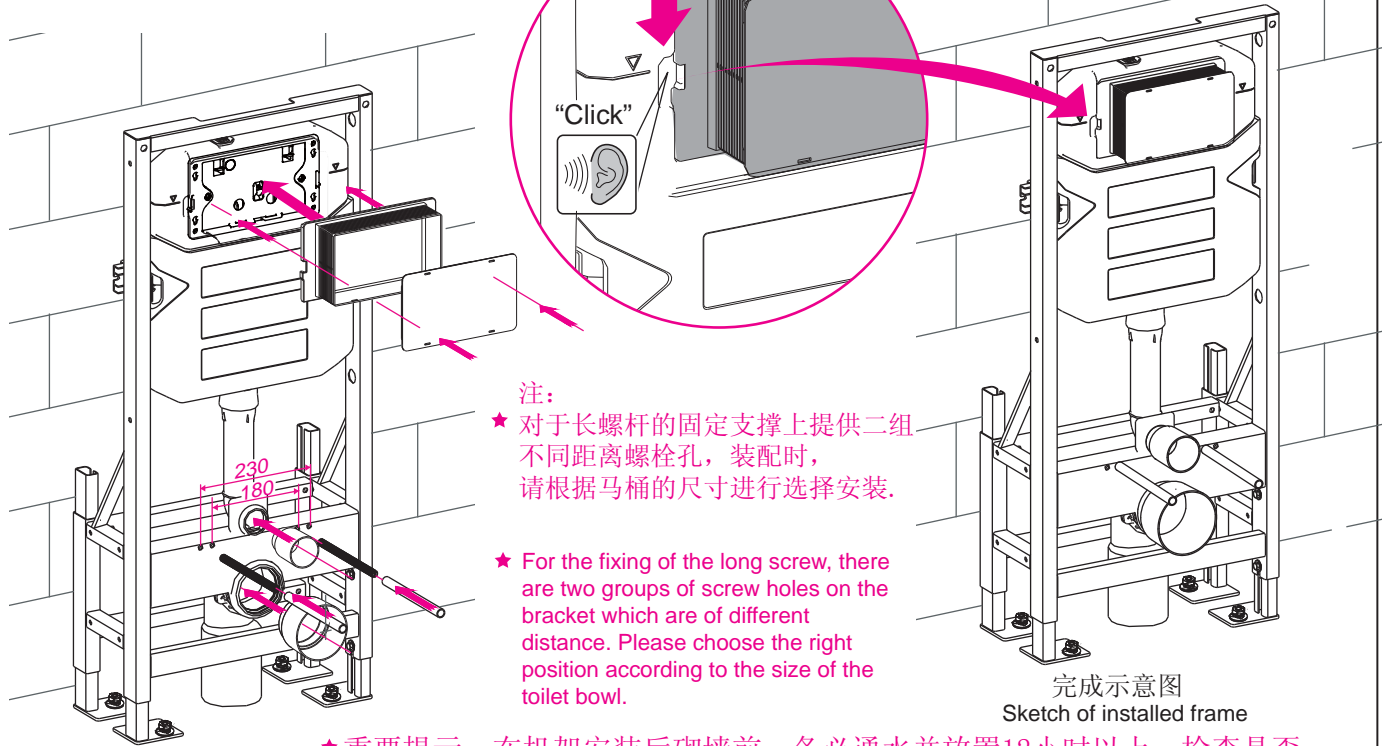

- ★ 重要提示: 在机架安装后砌墙前, 务必通水并放置12小时以上, 检查是否有渗漏现象。
- ★ Important remind: When the concealed tank fixed completely, it is important to test leaking with water upon 12 hours before fixing wall.

七、装修墙厚度范围20~60mm

(从固定机架外面算起, 到贴砖后完成面)

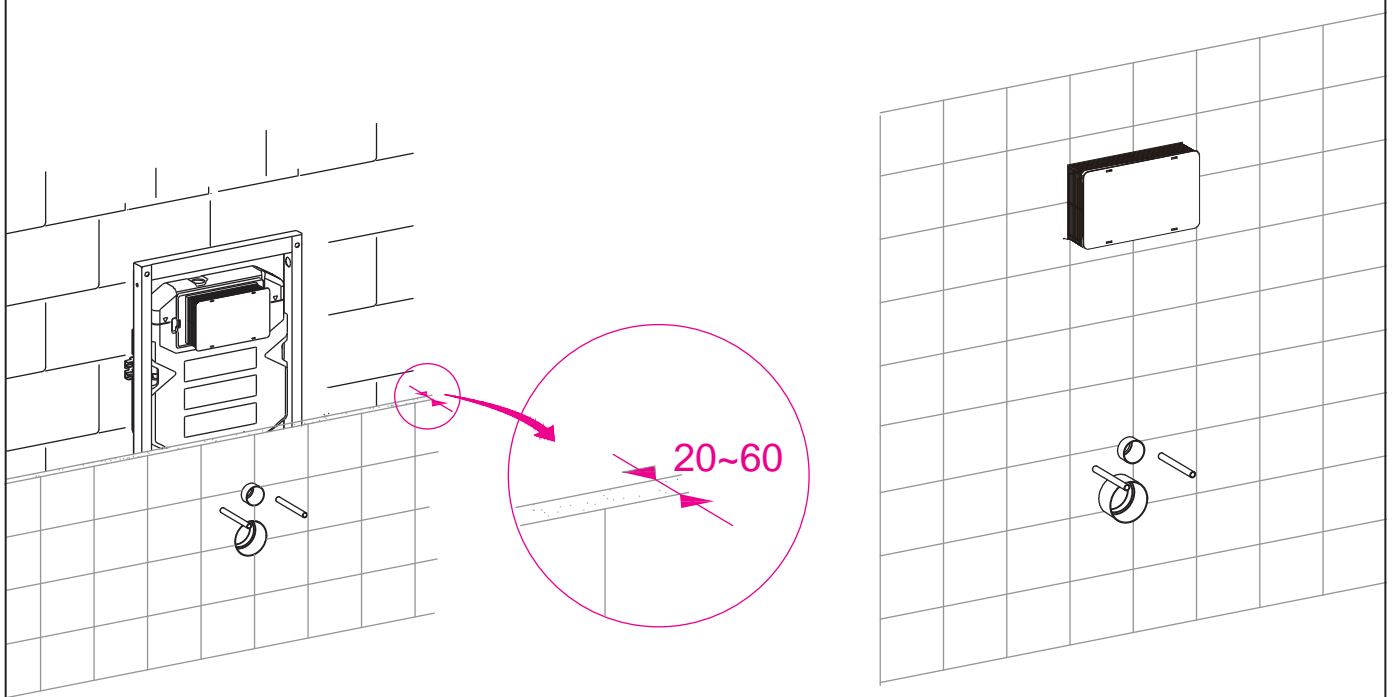

7.The thickness of fixed wall is 20~60mm

(measured from the front of frame to the finished tile surface)

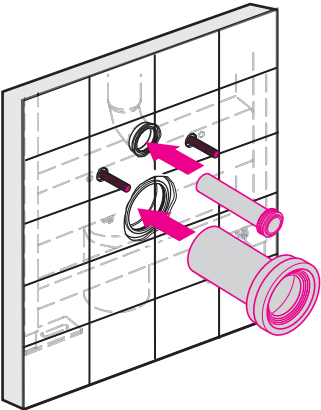
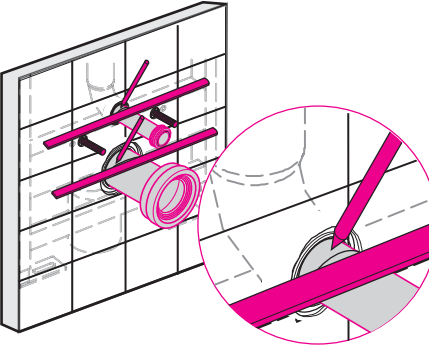
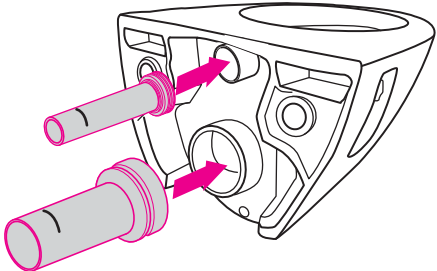
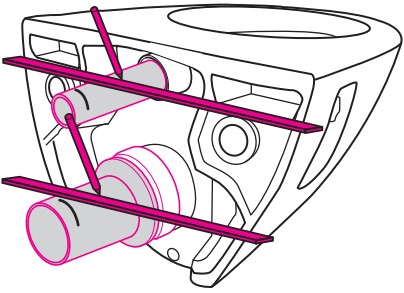
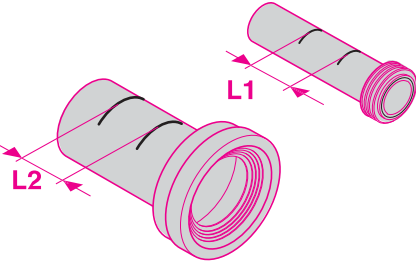
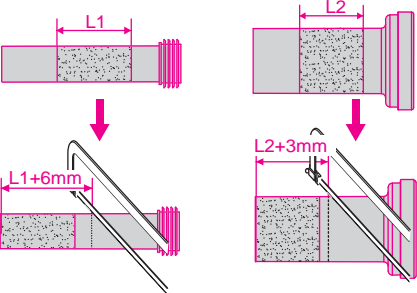
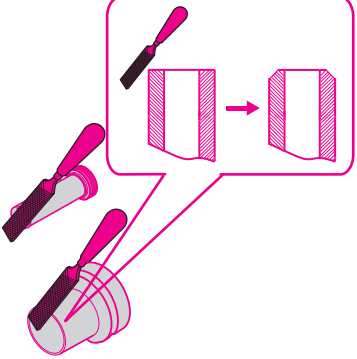
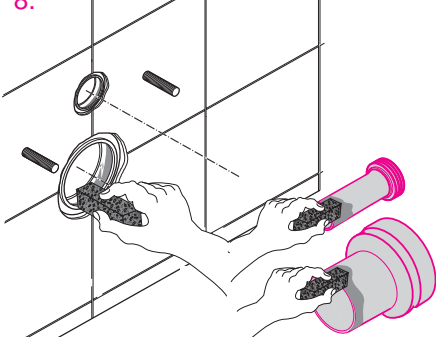

八、安装马桶:

8. Install toilet bowl :

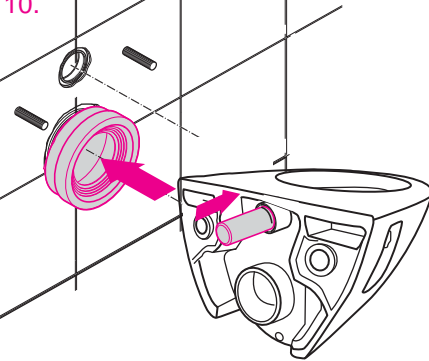
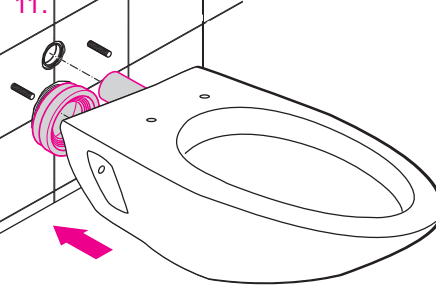
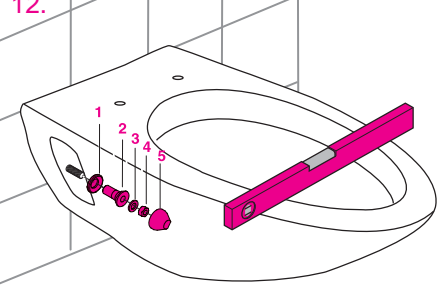
<p>1.</p> 	<p>2.</p>  <p>将直管分别插入冲水管和排水管到位,并画线标识。 Set Straight Pipes into Flush Bend and Drain Bend properly, and marks lines.</p>	<p>3.</p>  <p>分别在两根直管橡胶垫上抹上润滑油,再插入马桶。 (冲刷直管密封套安装方式见3.1、3.2、3.3) Add lubricant onto the Rubber Gaskets of two Straight Pipes and set them into Bowl. (Flush Pipe seal Gasket assembly see 3.1, 3.2 and 3.3)</p>
<p>4.</p>  <p>如图画线标识。 Mark lines as shows.</p>	<p>5.</p>  <p>冲水直管所画线标识之间L1; 排水直管所画线标识之间L2。 L1 is the distance of two marks on Flush Straight Pipe, and L2 is that of two marks on Drainpipe Straight Pipe.</p>	<p>6.</p>  <p>如图切割直管。 Cut Straight Pipe just as shows.</p>
<p>7.</p>  <p>将锯短的两管管口端面打磨倒角(如图),并去除毛边。 Chamfer and trim the cutting edges on the shortened Straight pipes (as shows).</p>	<p>8.</p>  <p>取出带有硅油海绵在直管与弯管的结合处抹上硅油。 Take out the sponge with silicon oil and smear it on connecting edges of Straight Pipe and Bends.</p>	<p>9.</p>  <p>螺杆调节长度为d+25mm(如图) Adjusting length for Bolt is d+25mm as shows.</p>
<p>10.</p>  <p>排水直管插入排水管,再将冲刷直管插入马桶孔。 First install Drain Straight Pipe into Drain Bend, and second install Flush Straight Pipe into Hole on Bowl.</p>	<p>11.</p>  <p>插入马桶。 Install Bowl.</p>	<p>12.</p>  <p>锁定。 Station Bowl properly.</p>

**3.1 冲刷直管密封套。
Flush Pipe Seal Gasket.**



密封套A
Seal Gasket A



密封套B
Seal Gasket B

**3.2 冲刷直管密封套A安装示意。
Seal Gasket A install**

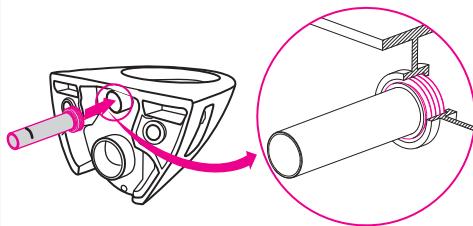

密封套安装时连同冲刷直管一起插入马桶孔内。
Seal Gasket A insert into Bowl with Flush Pipe together.

**3.3 冲刷直管密封套B安装示意。
Seal Gasket B install.**



密封套B安装:①首先须将密封套装入马桶孔;
②然后将冲刷直管塞进密封套B。
Seal Gasket B install: ①install the Gasket into Bowl first; ②then insert the Flush Pipe into the Seal Gasket.

九、水箱配件安装图:

9.Installation of tank fittings:

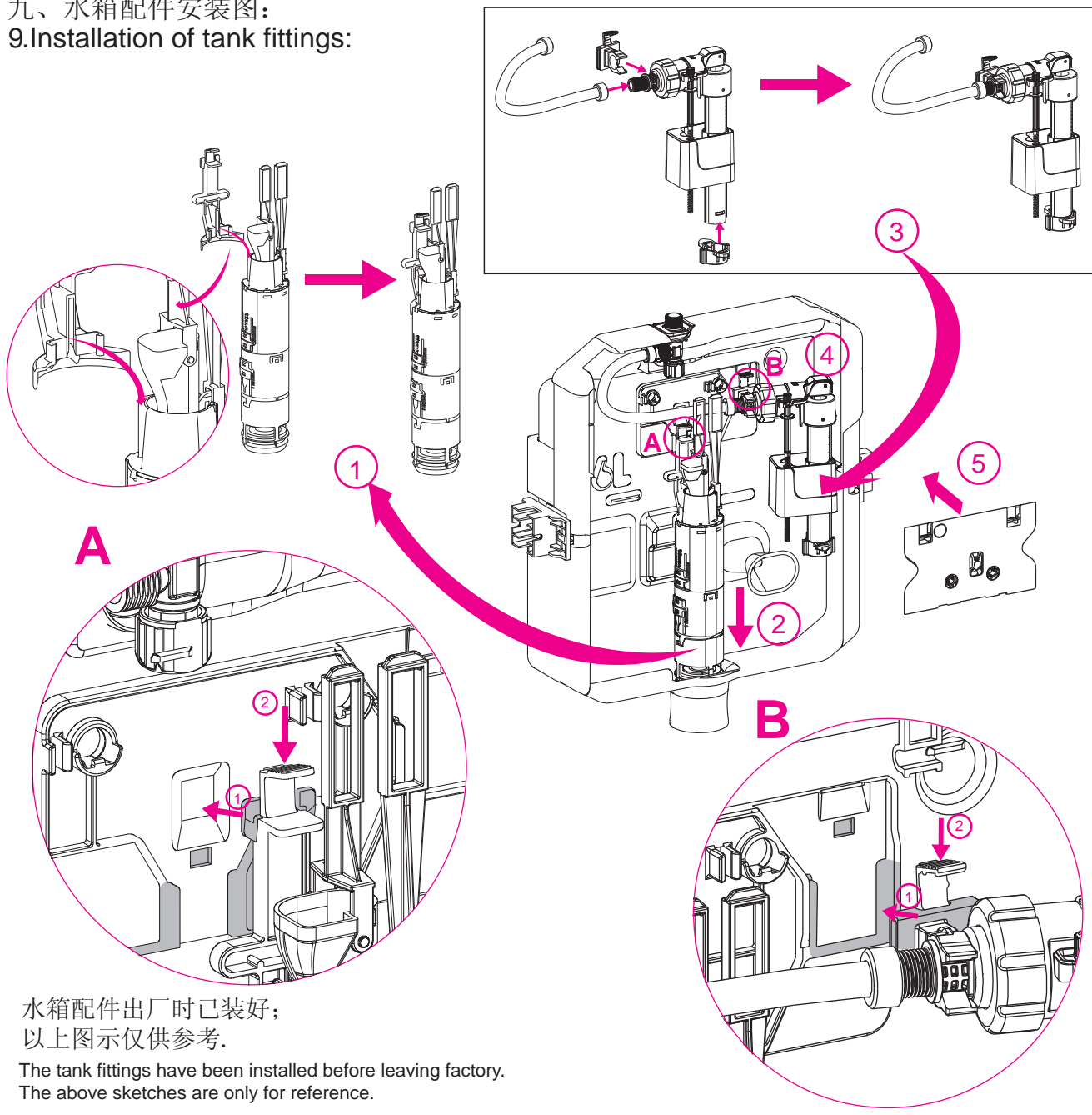

水箱配件出厂时已装好;
以上图示仅供参考。

The tank fittings have been installed before leaving factory.
The above sketches are only for reference.

所有的资料是按出版时的最新产品资料编写的, 本公司保留在任何时候不需通知便可更改产品的特征、包装或供应产品的权利。

All data contained is based upon the last product information available at the time of publication. We reserves the right to implement changes of product characteristics, packaging and availability at any time without further notice.

东陶(中国)有限公司
售后服务全国免费电话: 800-820-9787
手机用户: 400-820-9787

TOTO (CHINA) CO., LTD.
After Service Free Tel: 800-820-9787
Mobile telephone:400-820-9787